

Instructions:

- Battery (B+/-) ... the circuit is driven by two batteries in series. +12volts>+--<Common>+--<-12volts. (it is possible to drive this circuit from +/- 3.6volts to +/- 18volts)
- Motor M+/- : DC motors do not have polarity leads... connect leads either way
- LED connections : connect the west LED anode / East LED cathode to the top LED connection.
- The LEDs are connected in reversed parallel. The two west led anodes are connected to the two east led cathodes and vice versa. If the tracker rotates in the wrong direction simply reverse the LED connections at the PCB or reverse the DC motor connections.
- Sensor Mounting: The sensor must be mounted on the trackers axis of rotation. The sensor can be mounted away from the PCB and connected by a long lead. Make sure that the sensor has an unobstructed view of the sun thru 180deg rotation.
- Adjustment: The sensitivity is controlled by adjusting the potentiometer R2. The lower the resistance of R2 the more sensitive the tracker circuit is. If R2 is set to low the tracker will oscillate, if R2 is set to high the tracker will not respond. You can test the circuit using a flashlight or bright white LED light source.
- Caution: The circuit is designed to supply up to 1amp of current. Attempting to drive a larger load will burn out the power transistors Q1 or Q2.

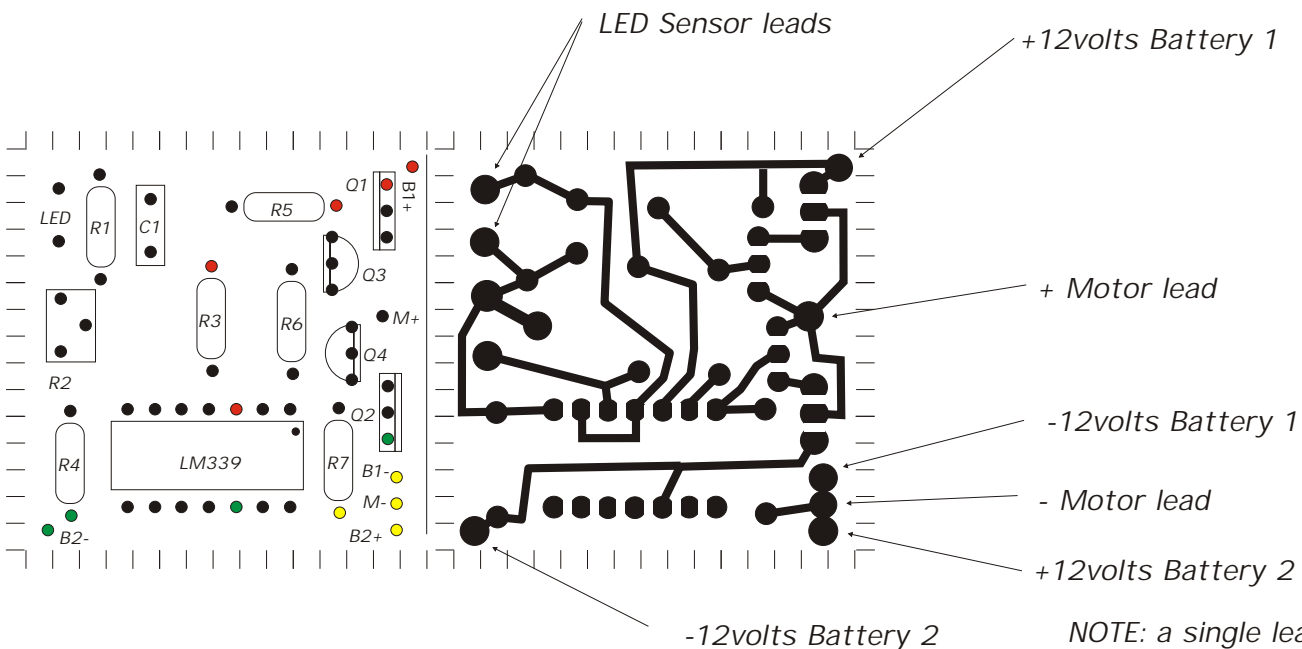

- Circuit Tested
- Sensor Tested

NOTE: a single lead is connected to the board as a common connection for M-, B1- and B2+